

# Strikes, Combination

10-255=10-055x10-027

**Jamb Type:** Wood  
**Style:** Combination  
**Standard for:**  
**Optional for:** H-Series | S200-Series

**NOTE:**

- When strike/frame reinforcer is used, additional preparation is required:  
 2 Pilot Holes and 1/8" (3) deeper mortise
- Dimensions X and Y are variables dependent on door thickness

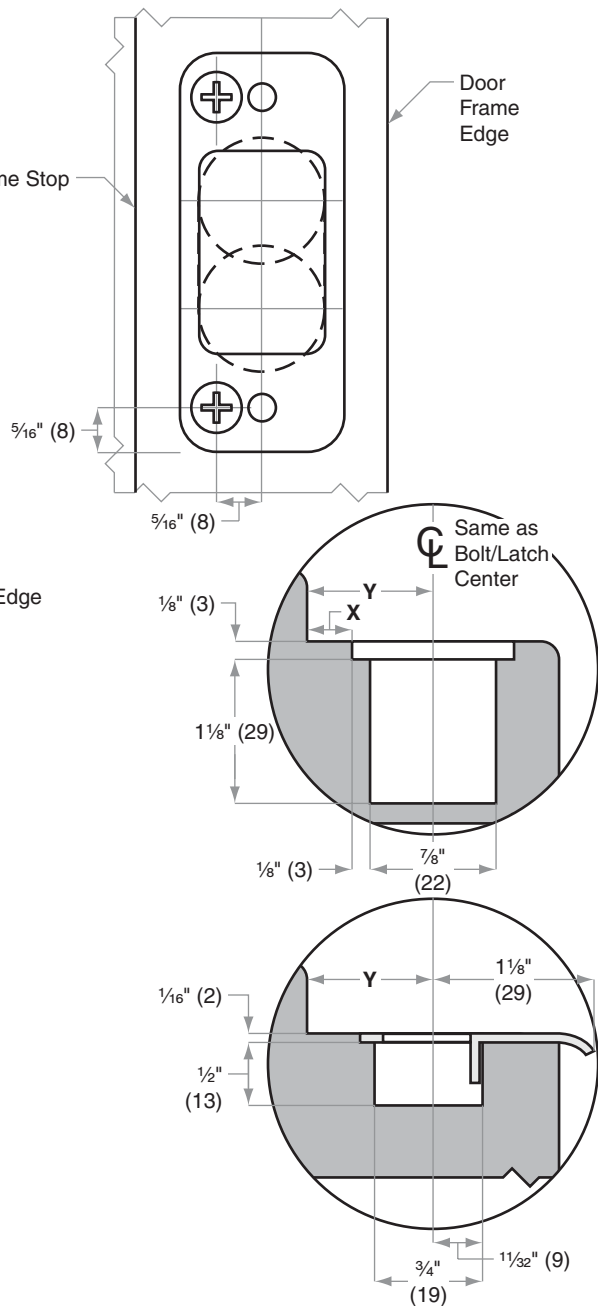
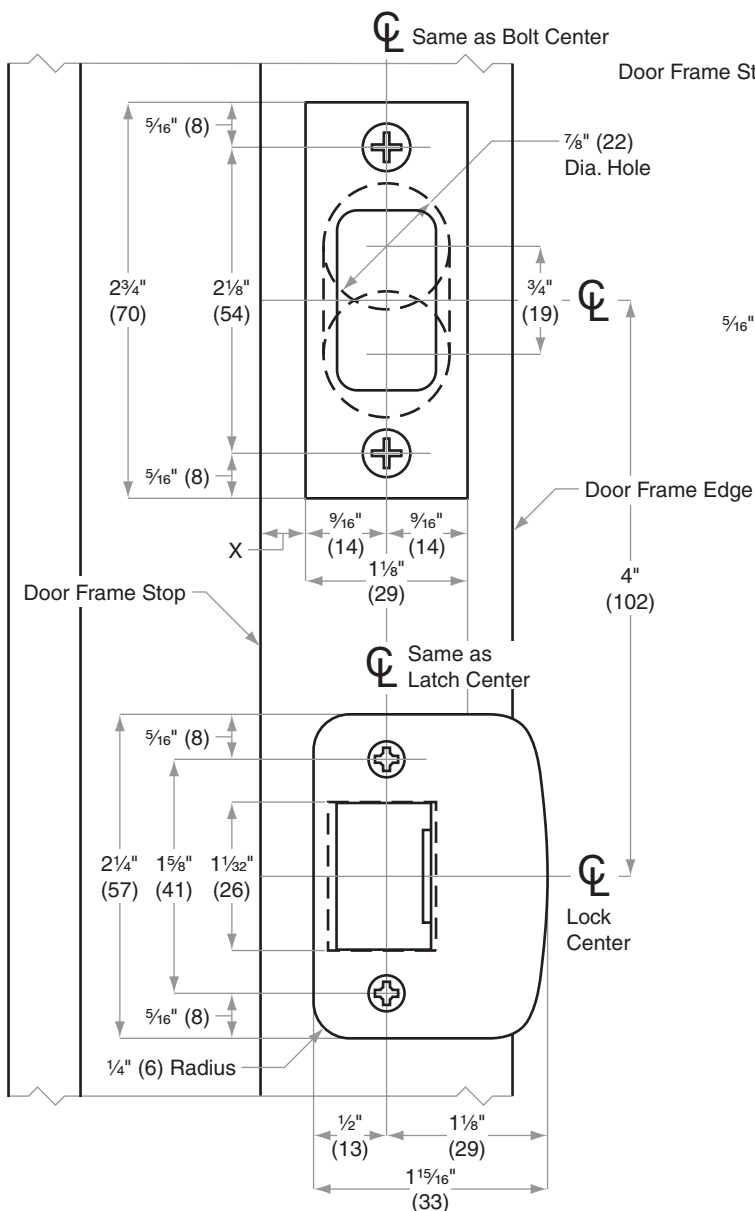

Dimensions shown in parentheses ( ) are in millimeters

**Job:** \_\_\_\_\_  
**Date:** \_\_\_\_\_  
**Door Thickness:** \_\_\_\_\_  
**Remarks:** \_\_\_\_\_

**TEMPLATE  
 J916**