

# L/LV-Series

## L0170

**Door Type:** Metal, flat or beveled

**Trim:** Rose

### Suitable reinforcement required for metal door installation

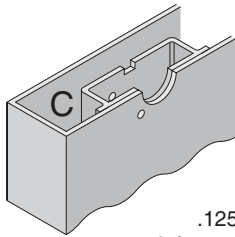
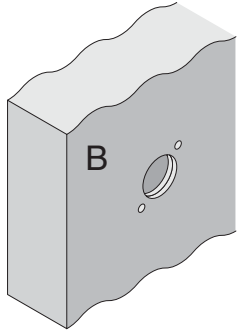

.125" (3) Steel Doubler reinforcement (not furnished)

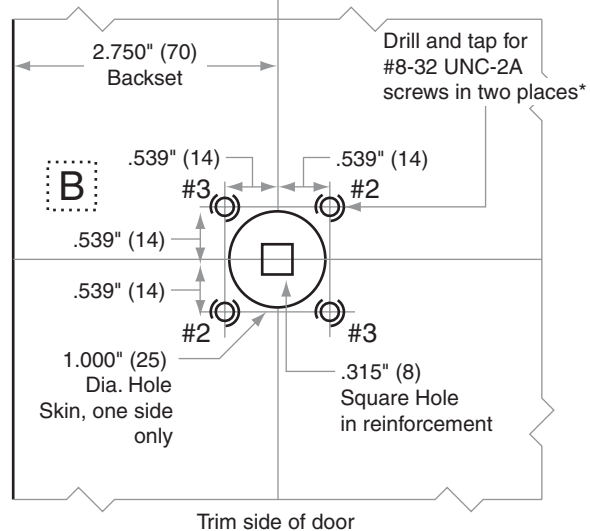
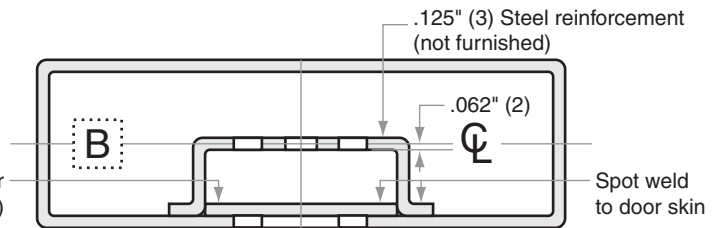

- \* Drill and tap two holes at locations #2 for outside RH/RHR or inside LH/LHR doors or
- Drill and tap two holes at locations #3 for outside LH/LHR or inside RH/RHR doors

Dimensions shown in parentheses ( ) are in millimeters

**Job:** \_\_\_\_\_

**Date:** \_\_\_\_\_

**Door Thickness:** \_\_\_\_\_

**Remarks:** \_\_\_\_\_

**TEMPLATE  
L781**