

# B500-Series

## B580

- Door Type:** Wood or Composite, Flat or Beveled
- Door Thickness:** 1 $\frac{3}{8}$ " (35mm)–2 $\frac{1}{4}$ " (57mm)
- Faceplate:** Round Corner,  $\frac{1}{4}$ " (6mm) Radius, 1" (25mm) wide
- Backsets:** B942-C, 2 $\frac{3}{8}$ " (60mm) | B942-D, 2 $\frac{3}{4}$ " (70mm) | B942-F, 5" (127mm)

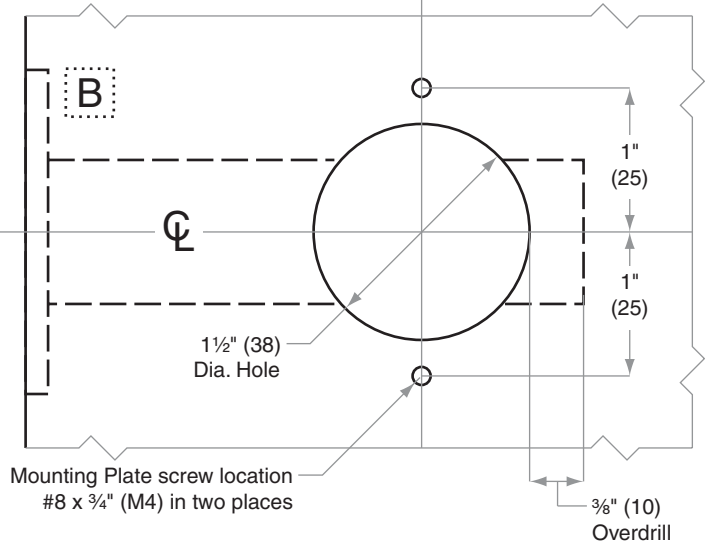
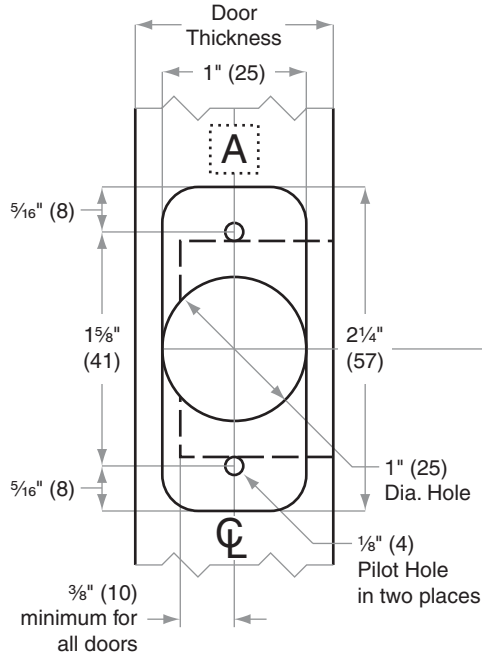
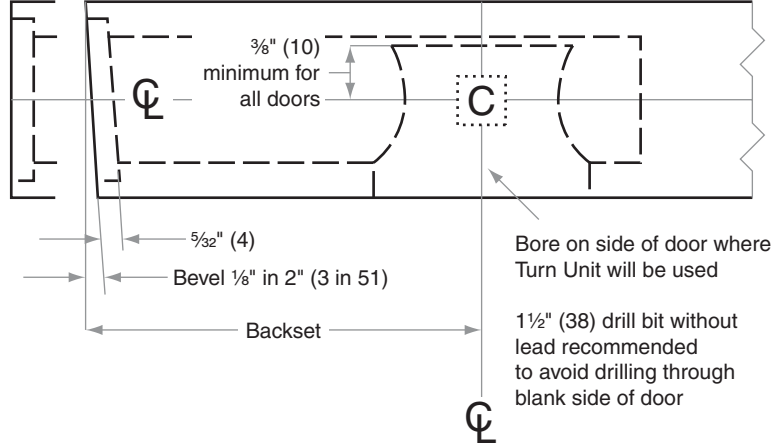
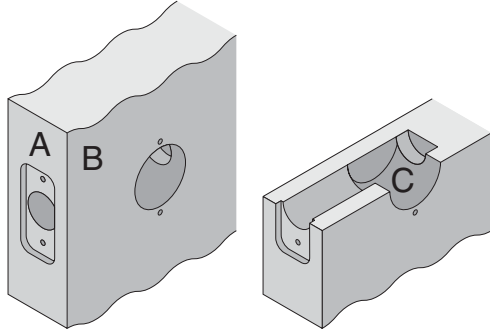

Dimensions shown in parentheses ( ) are in millimeters

**Job:** \_\_\_\_\_

**Date:** \_\_\_\_\_

**Door Thickness:** \_\_\_\_\_

**Remarks:** \_\_\_\_\_

**TEMPLATE**  
**B942**